

Profili ed accessori per realizzare separatori di gocce in alluminio, polipropilene ed acciaio inox.

Aluminium, polypropylene and stainless steel profiles and accessories to build mist eliminators.

Séparateurs de gouttes en aluminium, polypropylène et acier inoxydable: profils et accessoires.

Separadores de gotas en aluminio, polipropileno y acero inoxidable: perfiles y accesorios.

Aluminium, polypropylene und Edelstahl profilen und Zubehör für Tropfenabscheider.

铝和聚丙烯分离器下落：外形和附件。

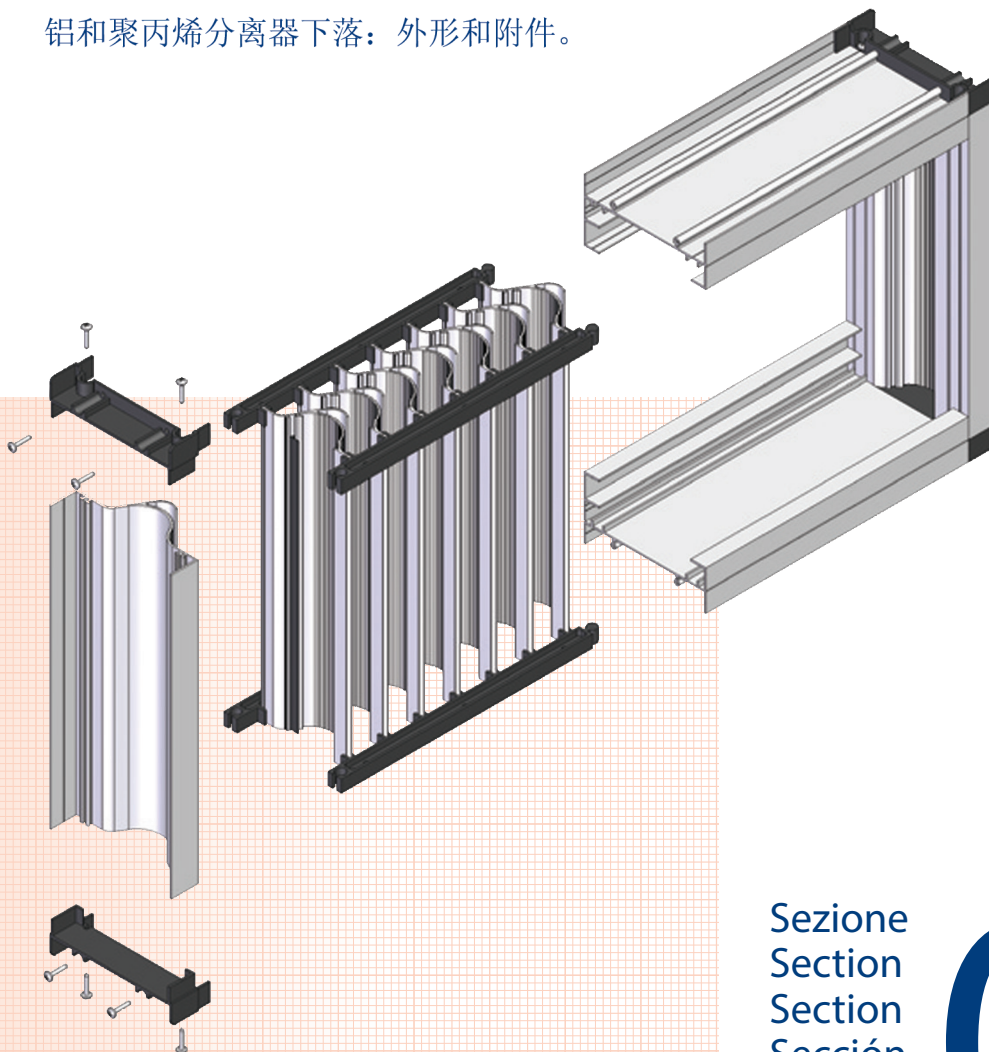

Sezione
Section
Section
Sección
Teil

第09号

09

Mist eliminators are available in two different versions: the first has aluminium blades (P 100 or P 180) and the second one has polypropylene blades (PP 106, PP 154 and PP 175).

They are assembled with the use of nylon “combs” that support the profiles in a vertical position and determine the distance between the separator profiles. The combs are available in different pitches: 25 mm (N 900), 40 mm (N 826) and 33 mm (N 901-33). They are used to position the mist eliminator profiles and must be placed at the bottom and at the top of the structure. In cases where separators used are particularly long, it is possible to place a “comb” in the middle of the structure as an additional support.

The mist eliminators have grooves where gasket (G 65) is placed to increase or decrease the surface of exchange and to modify the turbulence in order to split more or less water droplets from the air.

This system has the advantage of having two separators (P 100 and P 180) which can be used for different applications (air speed and drop diameter) as it is possible to decide their performance.

Another important point is that changes in performance are achieved through the variable “comb’s” pitch of 25, 33 or 40 mm.

The profiles P 100 and PP 106 can be assembled in their “special” frame by aluminium profiles P 110, P 111, P 112, P 113 with the corner A 140.

The unique characteristic of this frame is represented by the mist eliminator blade shape of the two corner post profiles. For this characteristic, the mist eliminator has an exclusively special efficiency. The post profiles have two functions at the same time: they support the frame and work as mist eliminator blade themselves.

The frame is very easy to assemble and it is solid even though in aluminium.

This section gives you some technical information about the characteristics of the mist eliminator. More technical data (on pressure drop, minimal diameter of the drop, air velocity, etc.) are available on request.

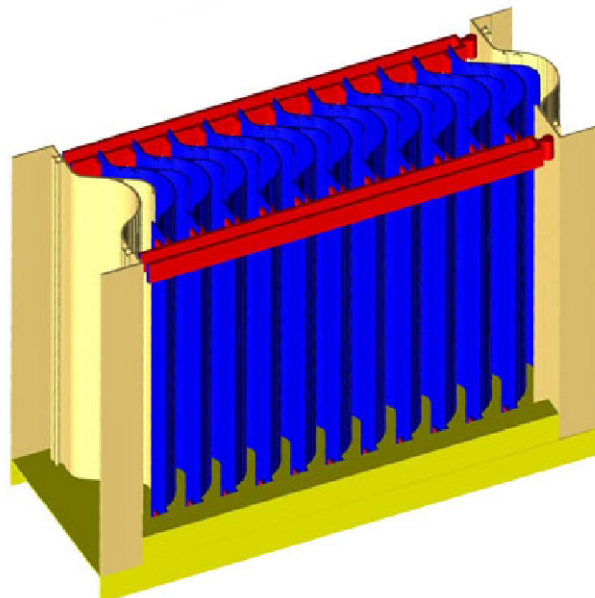

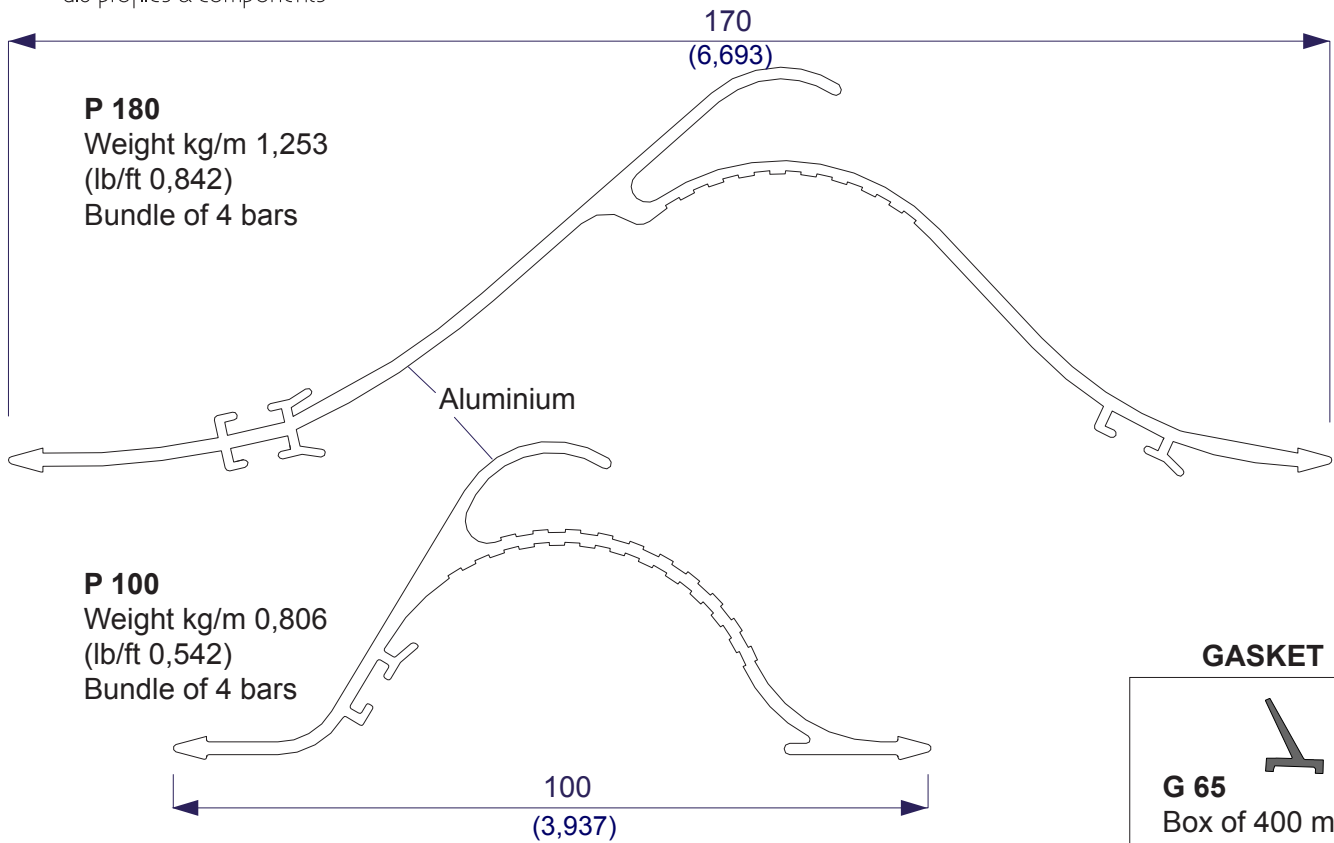

GASKET

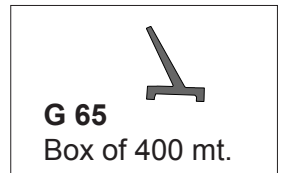

NYLON SPACER / SUPPORT

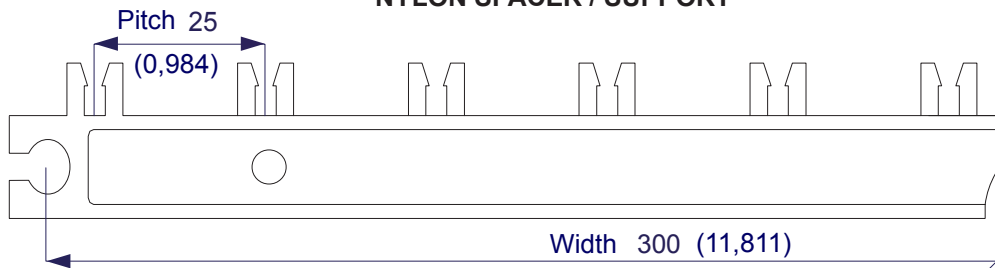

N 900
Box of 100 pcs.

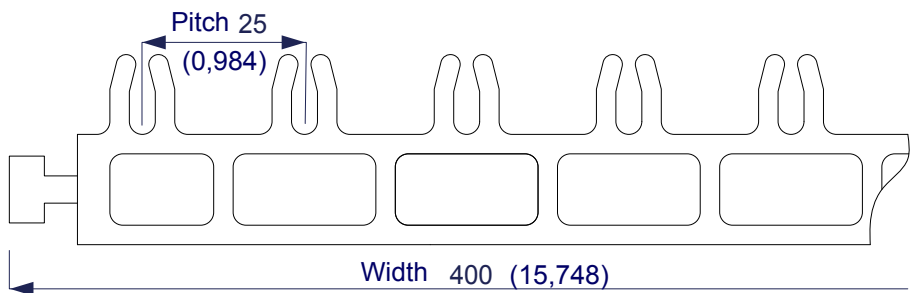

N 901-25
Box of 250 pcs.

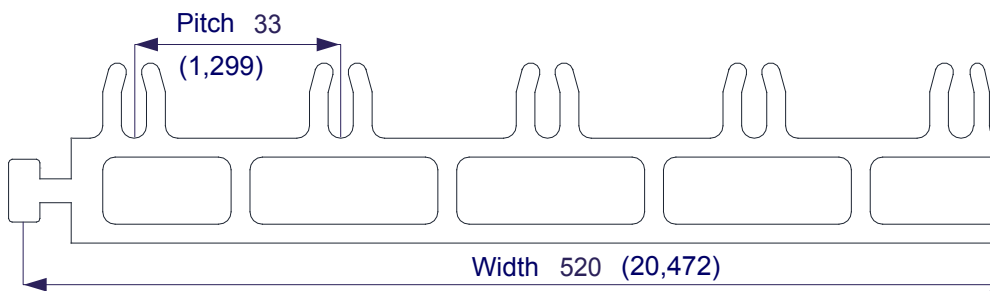

N 901-33
Box of 250 pcs.

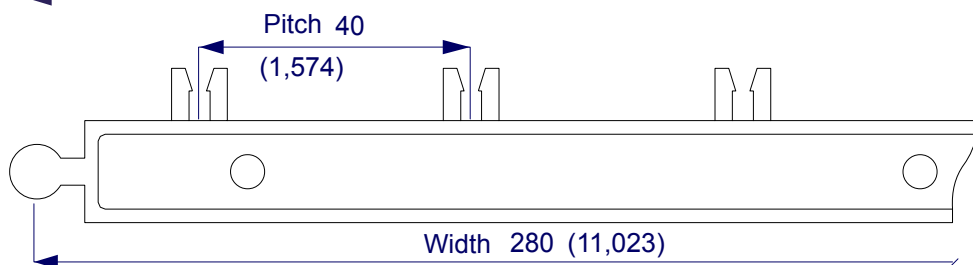

N 826
Box of 100 pcs.

MATERIAL POLYPROPYLENE

PP 106
Weight kg/m 0,291
Bundle of 4 bars

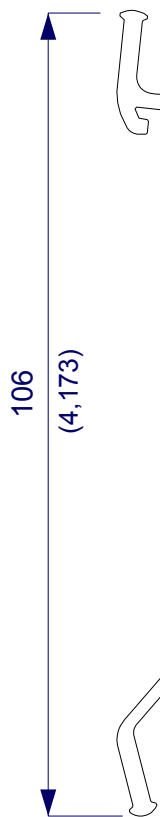

PP 175
Weight kg/m 0,411
Bundle of 4 bars

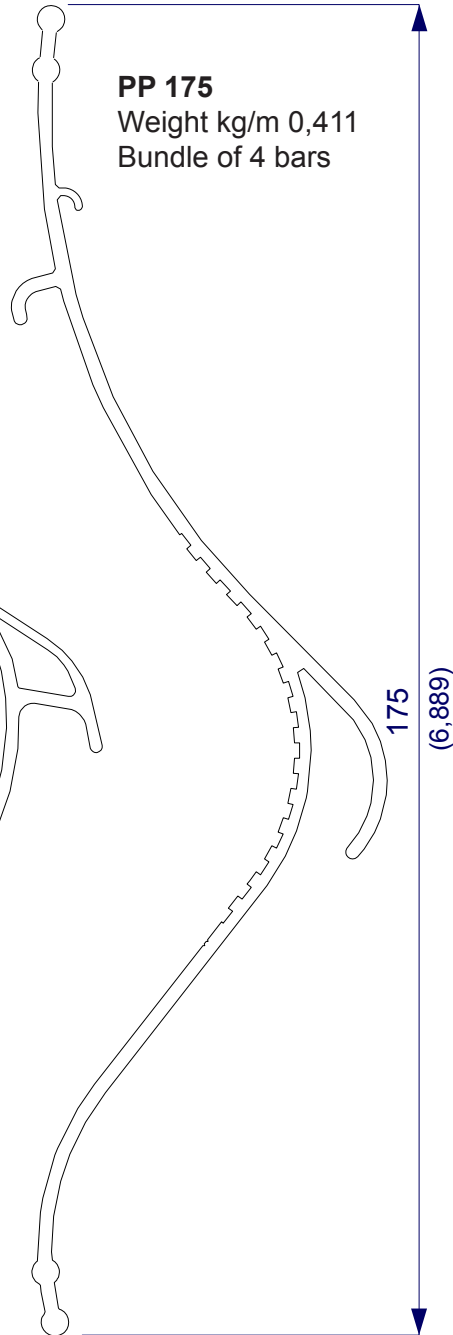

PP 154
Weight kg/m 0,417
Bundle of 4 bars

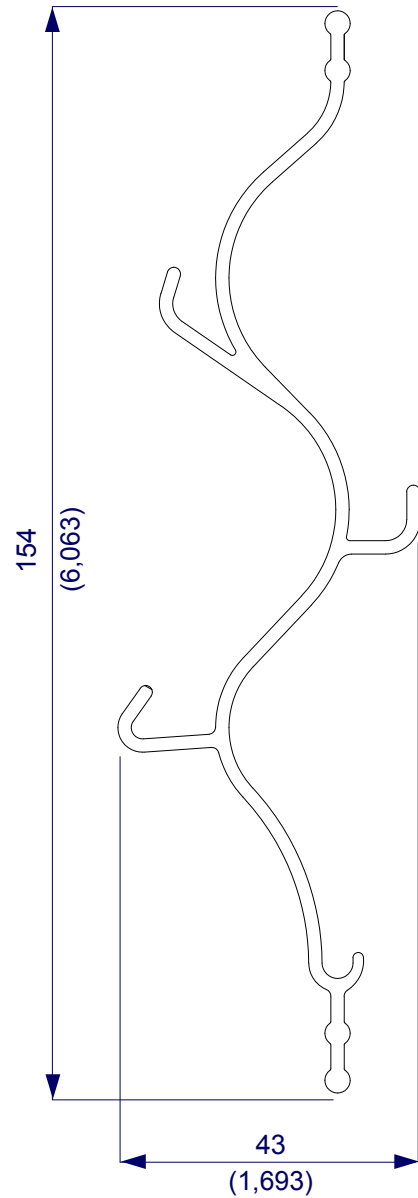

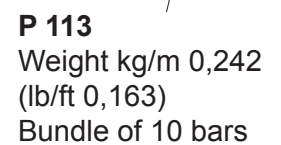
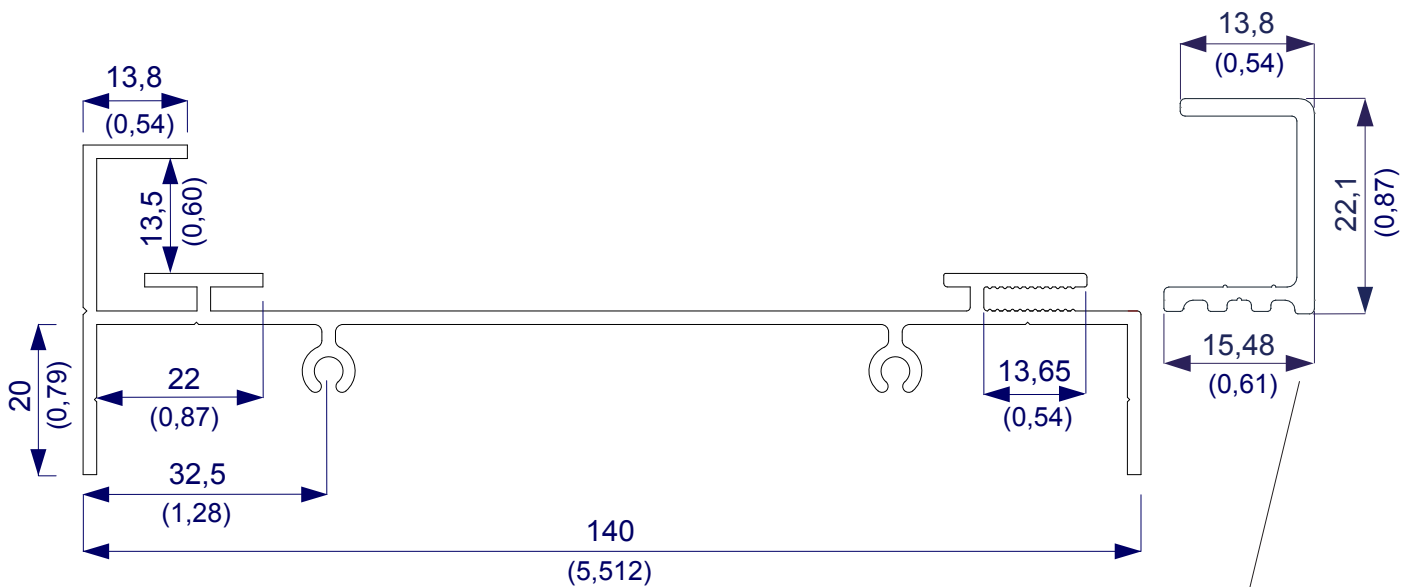
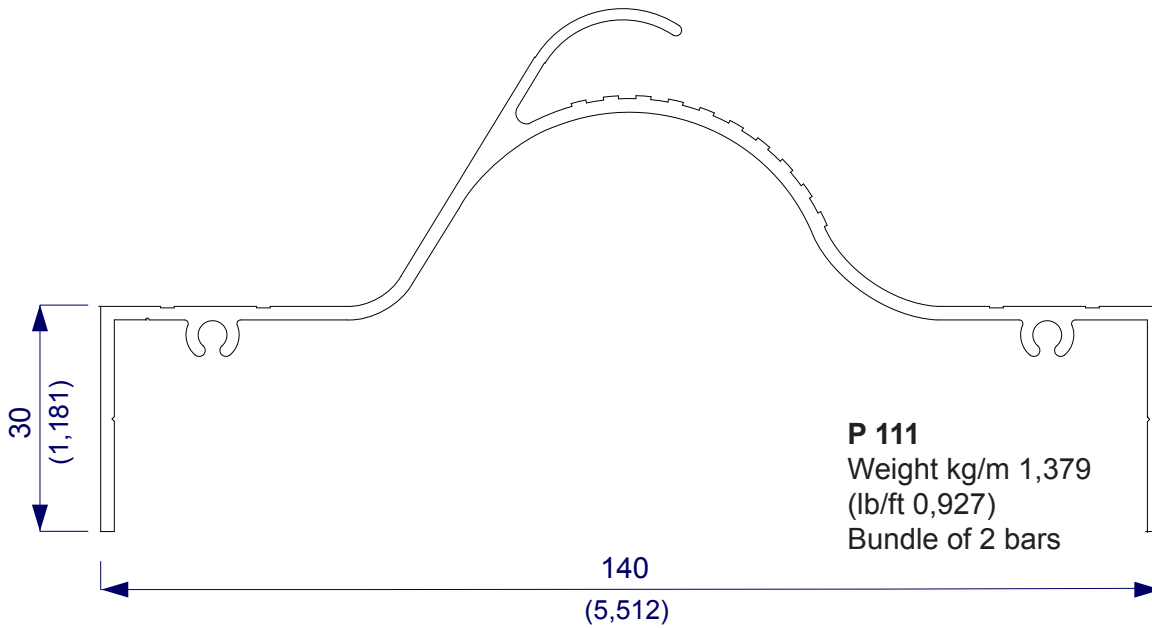
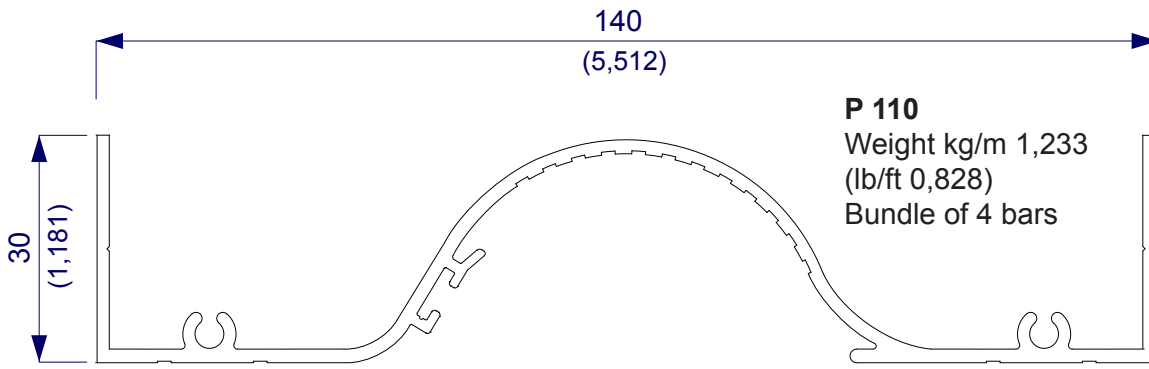

**3D representation of aluminium or polypropylene mist eliminator
assembled with the “special” frame P 110, P 111, P 112, P 113.**

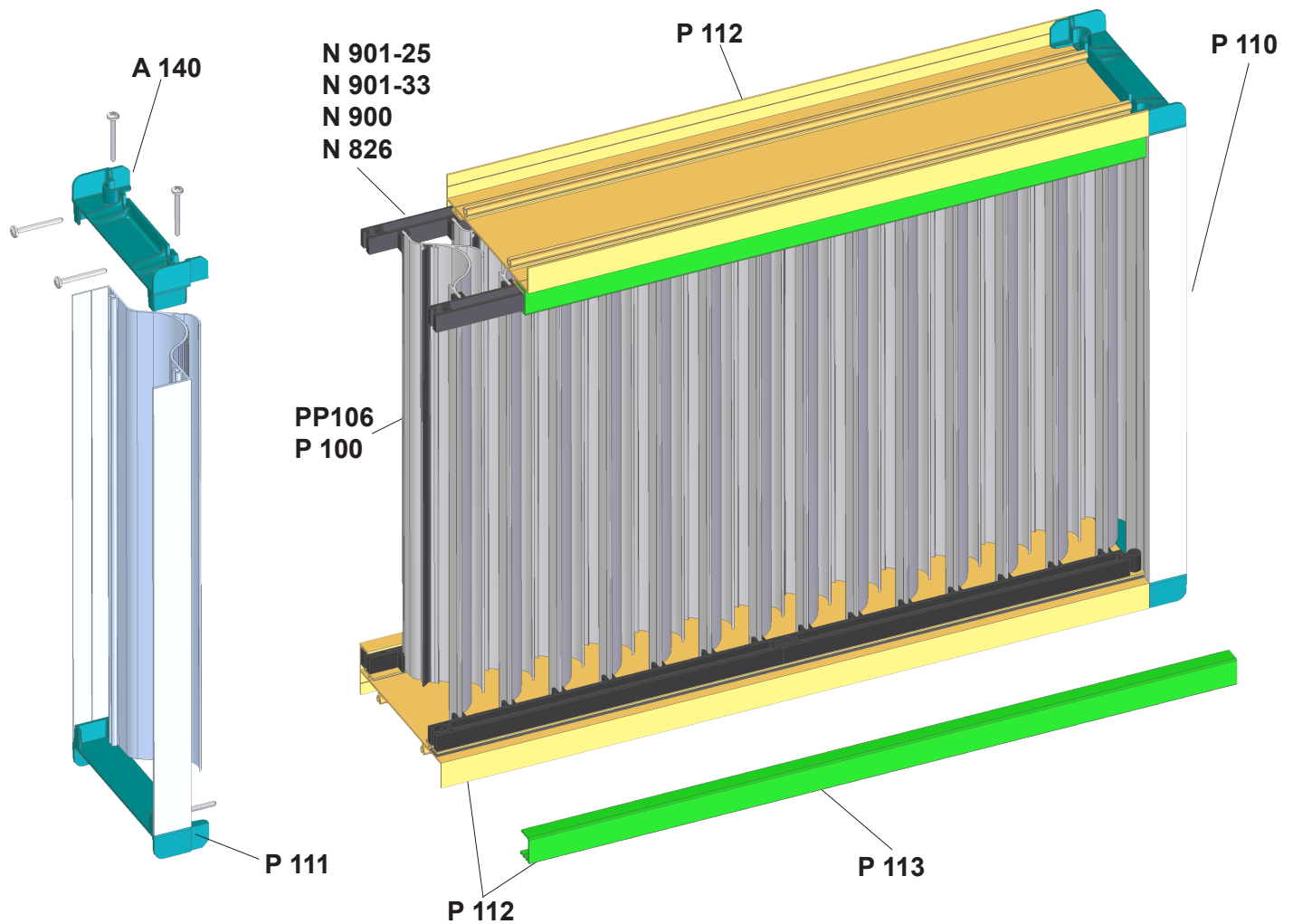

Aluminium corner for mist eliminator frame

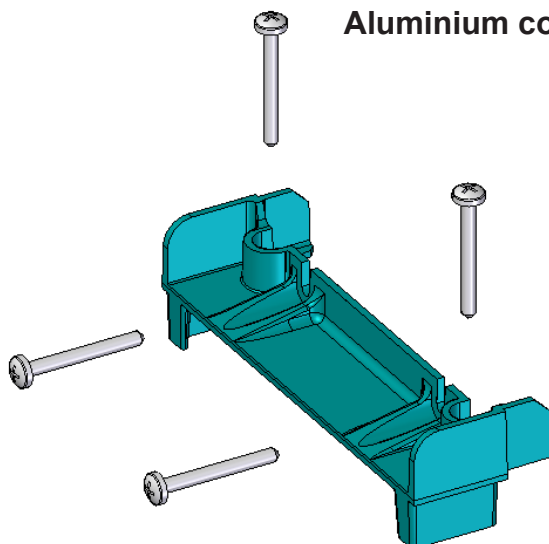

A 140
Box of 60 pcs.

FORMULA:

B (P 112 / P 113) = A - 60 mm

D (P 110 / P 111) = C - 44 mm

H blades (PP 106 / P 100) = C - 54

Number of blades PITCH 25 (N 900)

Number of blades = $(A - 77) : 25$ (result for defects always an integer)

Number of combs

E = number of blades : 12 (result for excess always an integer)

Number of combs (N 900) = E x 4

Number of blades PITCH 25 (N 901-25)

Number of blades = $(A - 77) : 25$ (result for defects always an integer)

Number of combs

E = number of blades : 16 (result for excess always an integer)

Number of combs (N 901-25) = E x 4

Number of blades PITCH 33 (N 901-33)

Number of blades = $(A - 77) : 33$ (result for defects always an integer)

Number of combs

E = number of blades : 16 (result for excess always an integer)

Number of combs (N 901-33) = E x 4

Number of blades PITCH 40 (N 826)

Number of blades = $(A - 77) : 40$ (result for defects always an integer)

Number of combs

E = number of blades : 40 (result for excess always an integer)

Number of combs (N 826) = E x 4

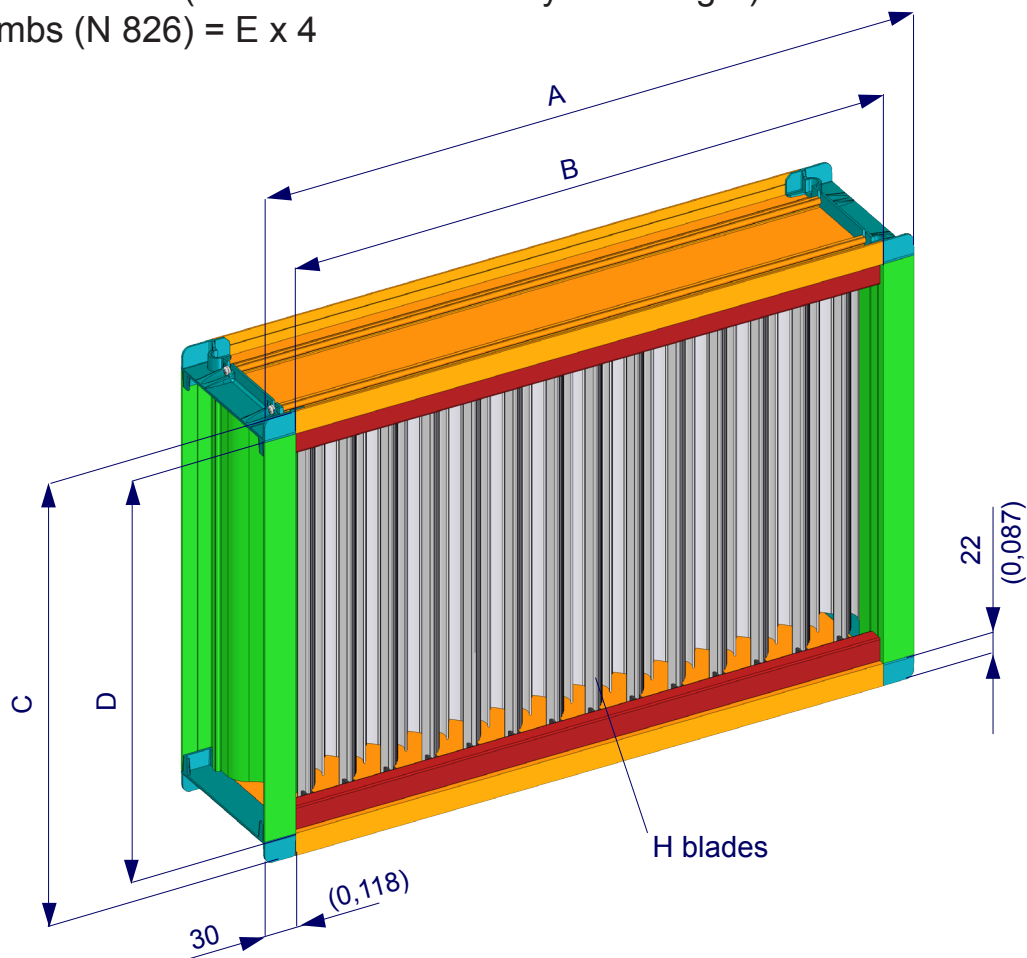

**3D representation of mist eliminator H 180 pitch 25 mm
(without gaskets)**

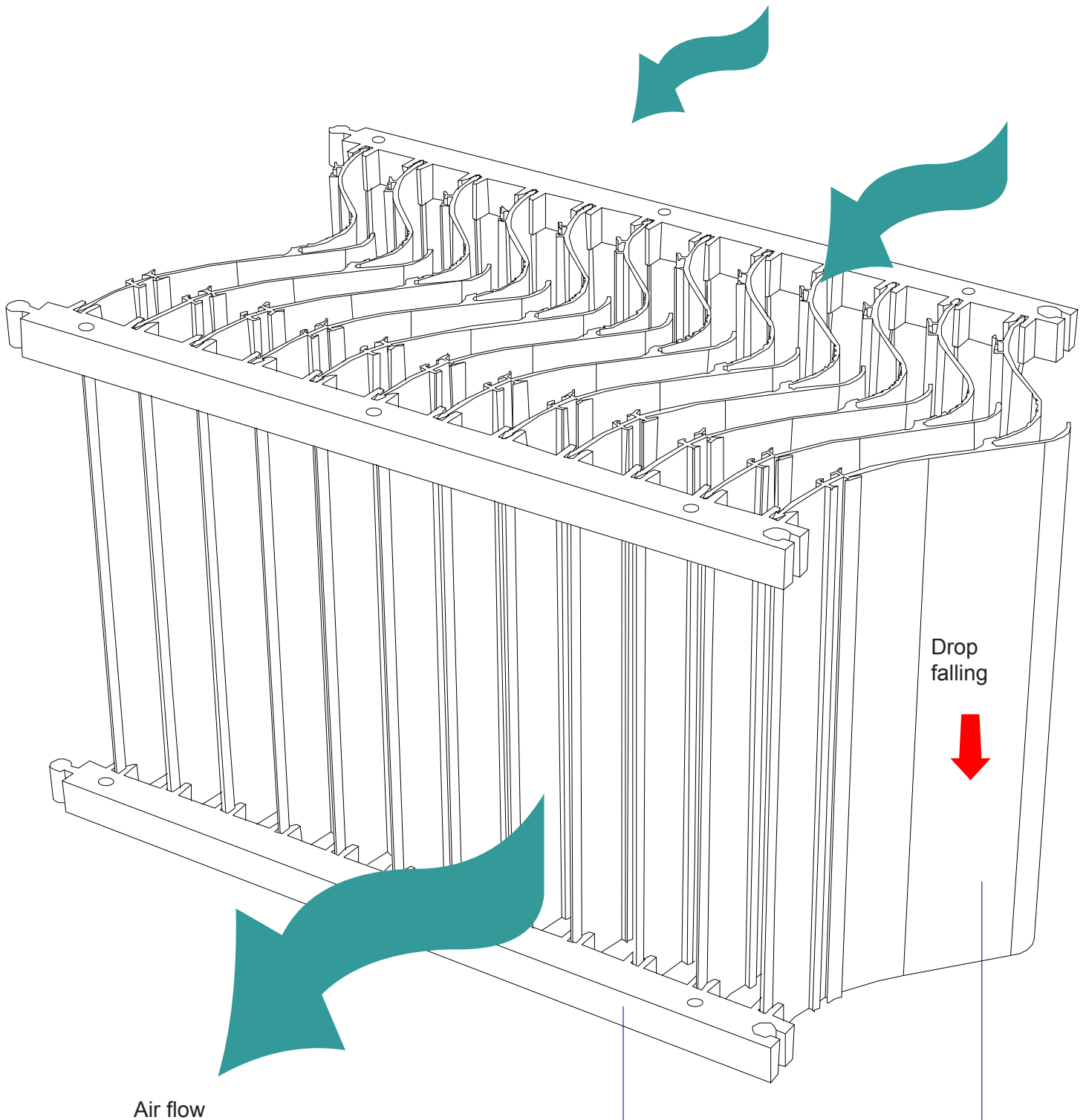

Air flow

Drop
falling

N 900
Pitch 25 mm
Box of 100 pcs.

P 180
Weight kg/m 1,253
(lb/ft 0,842)
Bundle of 4 bars

Aluminium mist eliminator

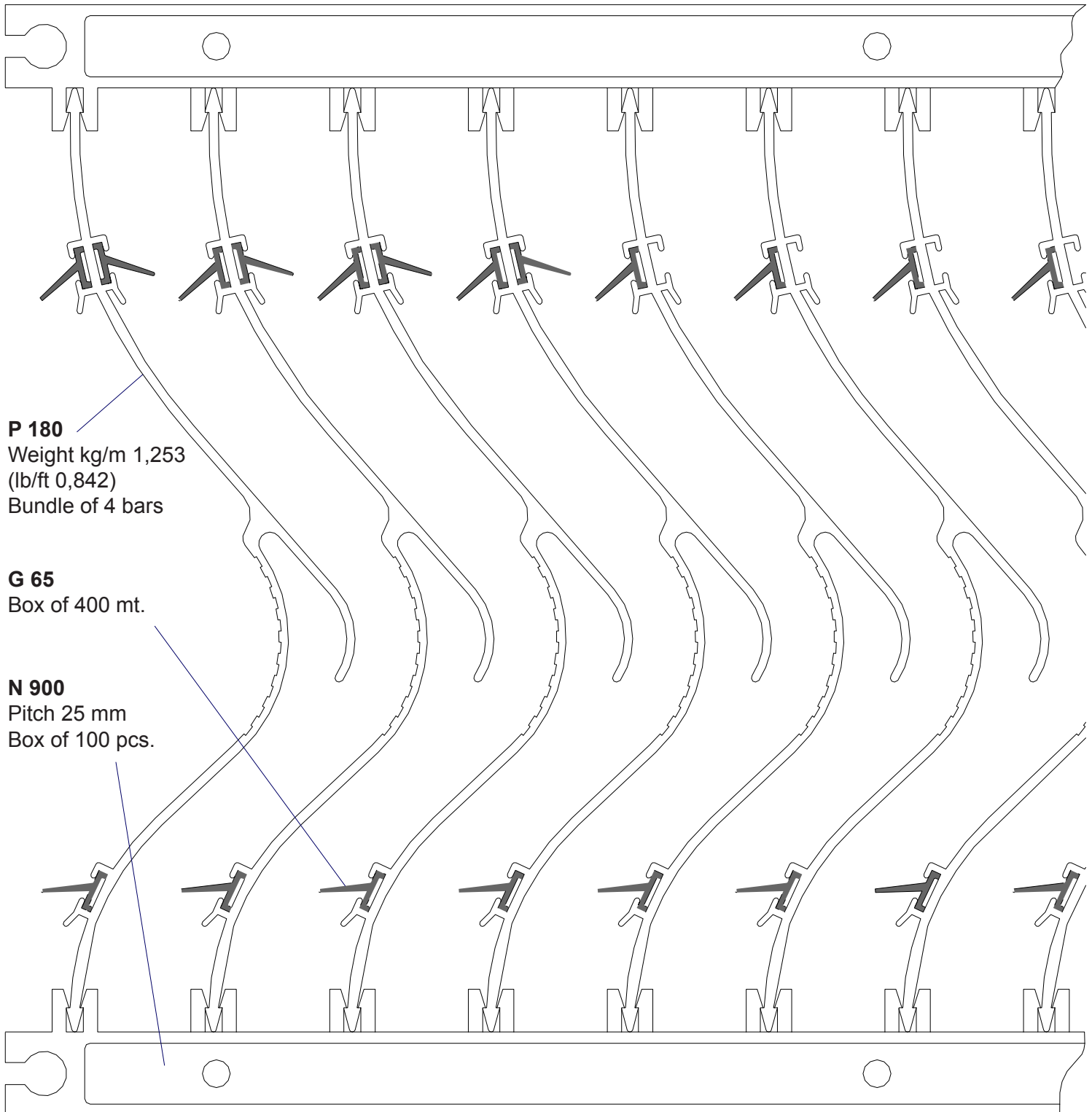

P 180
Weight kg/m 1,253
(lb/ft 0,842)
Bundle of 4 bars

G 65
Box of 400 mt.

N 900
Pitch 25 mm
Box of 100 pcs.

Way A

- Profile P 180 + 3 gaskets G 65.
- Range of application: Face velocity 1-2 m/sec.
- Air washer.
- Its main purpose is to remove the droplets at low face velocities.

Way B

- Profile P 180 + 2 gaskets G 65.
- Range of application: Face velocity 3-4 m/sec.
- Air washer.
- Air cooler.
- Its main purpose is to remove the droplets at low face velocities.

Aluminium mist eliminator

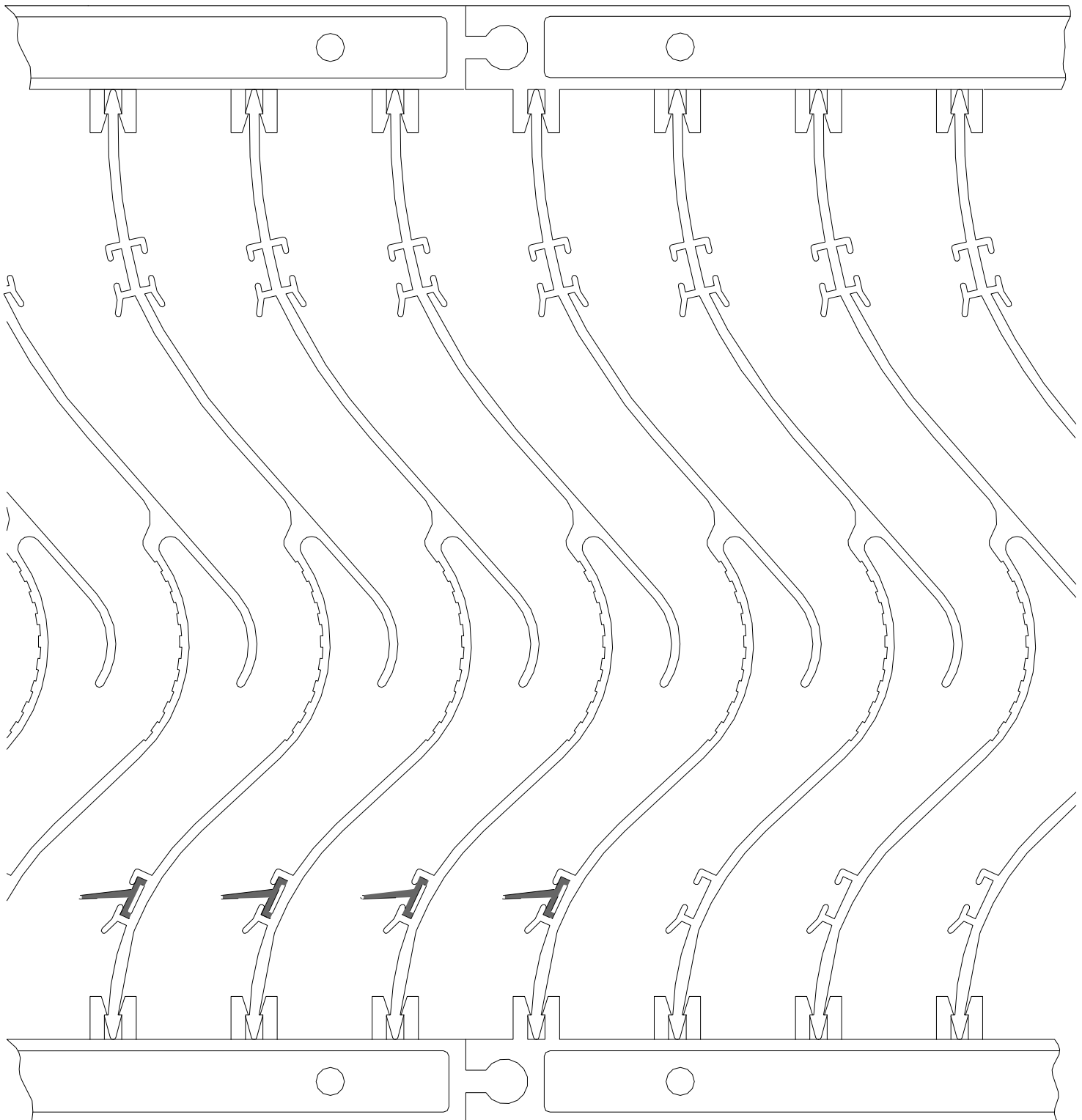

Way C

- Profile P 180 + 1 gasket G 65.
- Range of application: Face velocity 4-5 m/sec.
- Air cooler.
- Its main purpose is to remove the droplets entrained by the film of liquid formed on the cooling fins.

Way D

- Profile P 180.
- Range of application: Face velocity 5-6 m/sec.
- Air cooler.
- Its main purpose is to remove the droplets entrained by the film of liquid formed on the cooling fins.

2D representation of mist eliminator H 100 pitch 40 mm

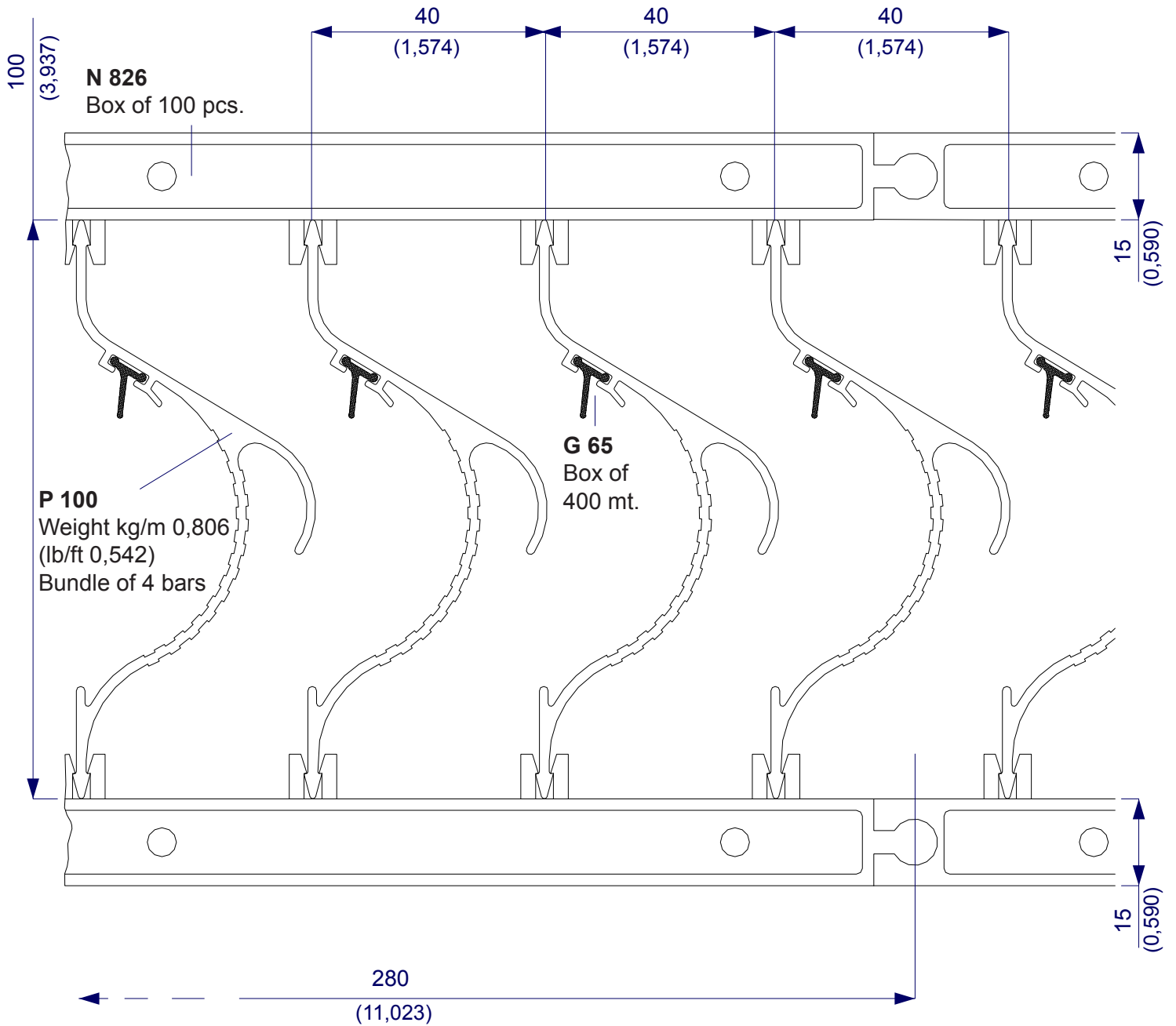

2D representation of mist eliminator H 100 pitch 25 mm

